

Affordable Automation for Welding, Cutting and Semi-Automatic Processes

CIR-O

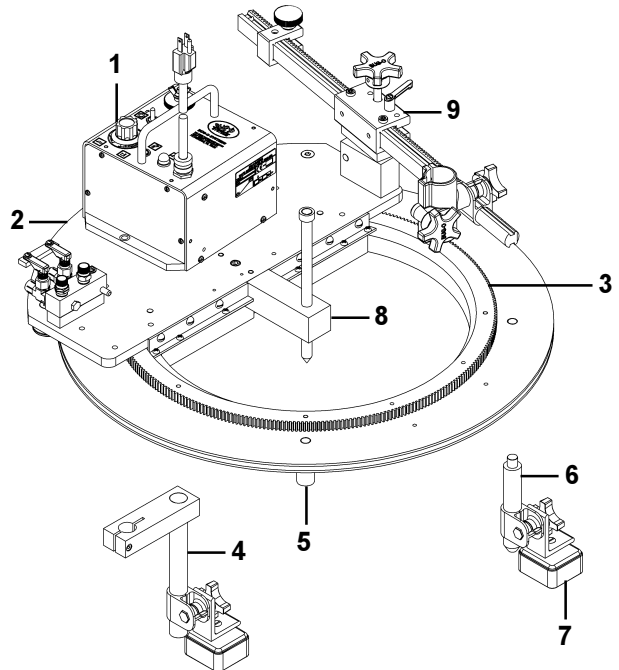
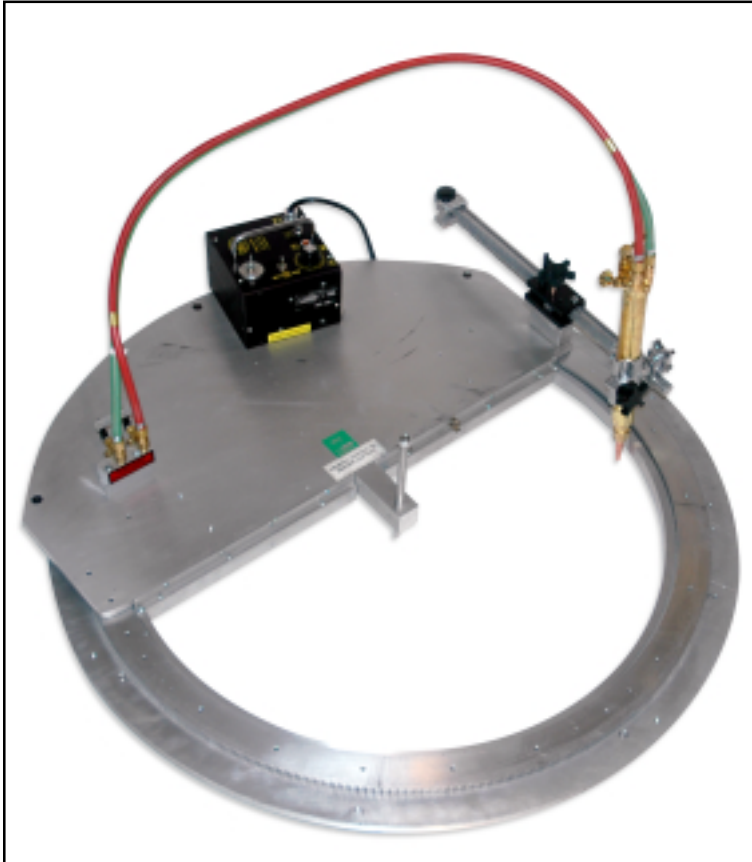

CIR-O machines are lightweight, heavy-duty, multiple-use circular drives. Each of the three sizes of machines has a positive rack and pinion drive and infinitely variable speed control which provides smooth, accurate travel in all positions. The carriage provides a mounting surface for a variety of different process tools. A single center-punch mark is all that is needed to locate the machine on the workpiece. It is then ready to flame-cut, bevel or weld. Permanent magnets or vacuum cups can be purchased separately to hold it in place.

1. **BUG-5100-F** drive unit provides the power with a solid-state variable speed control.
2. **CIR-3040**, **CIR-4040** and **CIR-5040** carriage insures accurate work paths by meshing firmly with the gear. A quick-acting manifold with a short connection hose, and a centering pin are mounted on the carriage.
3. **CON-3000**, **CON-4000**, **CON-5000** ring and gear assembly with its perfectly round cut gear makes every cut true.
4. **OPTIONAL CIR-9002** offset leg and magnet assembly - four of these units are used to eliminate the blind spot under the ring. Each unit clamps onto a standard leg. An adjustable tip adaptor must be used to offset the cutting tip under the ring.
5. Standard 2" (50 mm) leg [four supplied with the machine].
6. **OPTIONAL CIR-9021** 5" (127 mm) leg [use with template kit and CIR-9020 magnet foot].
7. **OPTIONAL CIR-9020** magnet foot [use with CIR-9021 5" (127 mm) leg] locks machine to work - four required.
8. Center location with stainless steel center pin.
9. Rotating post mount - this combination of modules provide accurate positioning of a torch for any single torch operation.



BUG-O SYSTEMS
A DIVISION OF WELD TOOLING CORPORATION



3001 WEST CARSON STREET PITTSBURGH, PENNSYLVANIA USA 15204-1899
PHONE: 1-800-245-3186 <http://www.bugo.com> TELEFAX: 1-412-331-0383



CIR-O HEAVY DUTY CIRCLE CUTTER

Capacities and Speed Ranges

Dimensions:

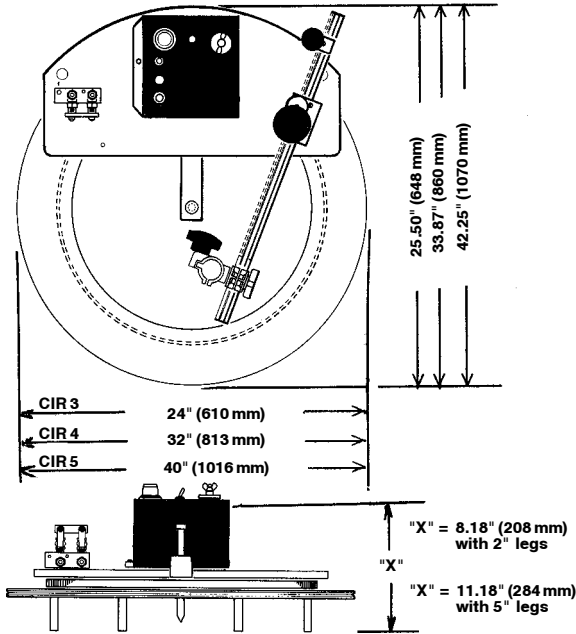

NOTE: Torches, tips and magnets or vacuum cups must be ordered separately.

PART NUMBER	POWER REQUIREMENT	PART NUMBER	SHIPPING WEIGHT	NET WEIGHT
CIR-3303	120 VAC/50-60-1	CIR-3303	66 lbs. (30.0 kg)	48 lbs. (21.8 kg)
CIR-3323	240 VAC/50-60-1	CIR-3323		
CIR-3313	42 VAC/50-60-1	CIR-3313		
CIR-4404	120 VAC/50-60-1	CIR-4404	90 lbs. (40.8kg)	65 lbs. (29.5 kg)
CIR-4424	240 VAC/50-60-1	CIR-4424		
CIR-4414	42 VAC/50-60-1	CIR-4414		
CIR-5505	120 VAC/50-60-1	CIR-5505	128 lbs. (58.0 kg)	90 lbs. (40.9 kg)
CIR-5525	240 VAC/50-60-1	CIR-5525		
CIR-5515	42 VAC/50-60-1	CIR-5515		

	INSIDE DIAMETER	OUTSIDE DIAMETER
CIR-3303 CIR-3323 CIR-3313	3"-14" (75-356 mm)	26"-56" (660-1422 mm)
CIR-4404 CIR-4424 CIR-4414	3"-22" (75-559 mm)	34"-64" (864-1626 mm)
CIR-5505 CIR-5525 CIR-5515	3"-30" (75-760 mm)	42"-72" (1060-1830 mm)

		DIAMETER		DIAMETER		
		INCH	IPM	MM	MM/MIN	
CIR-III	INSIDE RING	3	.4-8	75	10-210	
		6	.8-16	150	20-420	
		10	1.4-28	250	35-700	
		14	2-39	350	50-1000	
		CIR-III	OUTSIDE RING	26	3.5-70	650
30	4-80			750	105-2100	
34	4.5-92			850	120-2400	
38	5.2-105			950	130-2640	
42	5.7-115			1050	50-3000	
46	6.3-125			1140	60-3200	
50	6.8-135			1250	175-3500	
CIR-IV	INSIDE RING	3	.3-5	75	7-140	
		6	.6-11	150	14-280	
		10	.9-18	250	23-460	
		14	1.3-26	350	32-650	
		18	1.7-33	450	42-840	
CIR-IV	OUTSIDE RING	22	2-40	550	50-1000	
		34	3.2-63	850	80-1600	
		38	3.5-70	950	87-1760	
		42	3.9-78	1050	97-1950	
		46	4.3-85	1150	105-2130	
		50	4.6-93	1250	115-2300	
		54	5-100	1350	125-2500	
		58	5.4-110	1450	135-2700	
		64	6-120	1625	150-3000	
		CIR-V	INSIDE RING	3	.2-4	75
6	.4-8			150	10-210	
10	.7-13			250	17-350	
14	1-19			350	24-500	
18	1.3-25			450	32-640	
22	1.5-30			550	38-760	
CIR-V	OUTSIDE RING		26	1.8-37	650	45-900
			30	2-41	750	52-1050
			42	2.9-57	1050	73-1458
			46	3.2-63	1150	80-1600
CIR-V	OUTSIDE RING	50	3.4-68	1250	87-1750	
		54	3.7-75	1350	94-1900	
		58	4-80	1450	100-2000	
		62	4.3-85	1550	105-2150	
		66	4.5-90	1650	115-2300	
		72	4.9-100	1825	125-2500	

Optional Accessories:

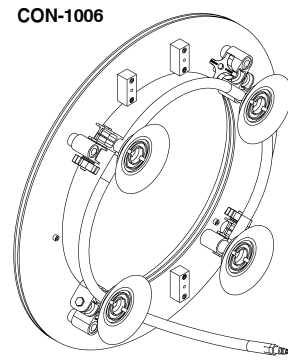
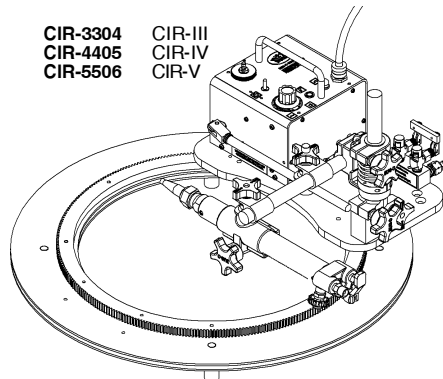
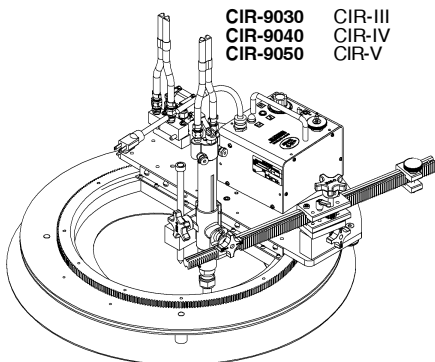

TEMPLATE KIT - consists of a sheet aluminum master template, alignment bars, spacer legs, tensioning assembly and torchholder. Pattern is cut in tempered hardboard and bolted to ring.

ANNULAR CARRIAGE - for special welding and cutting applications - when material to be cut or welded passes through the ring track.

VACUUM MOUNTS - CON-1006 for use on non-ferrous material such as stainless, aluminum etc. Use with ARV-2020 Vacuum Pump Kit.